

THIS DRAWING IS UNPUBLISHED. RELEASED FOR PUBLICATION 20
 © COPYRIGHT 20 BY - ALL RIGHTS RESERVED.

LOC		DIST		REVISIONS			
P	LTR	DESCRIPTION		DATE	DWN	APVD	
	G	REVISED PER ECO-15-003291		27JUL2015	SC	DZ	

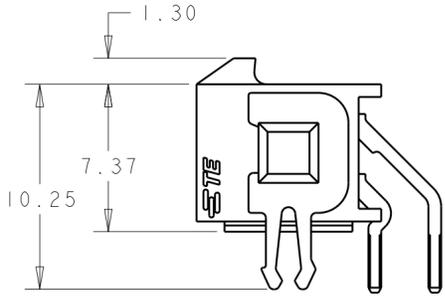

- 1 MATERIAL;
CONTACTS - BRASS.
HOUSING - UL 94V-0 RATED HIGH TEMP NYLON, COLOR; BLACK.
- 2 PLATING;
CONTACTS - 0.38µm MINIMUM GOLD OVER 2.54µm MINIMUM NICKEL ON MATING AREA. 2.54µm TIN-LEAD MINIMUM OVER 2.54µm NICKEL MINIMUM ON SOLDER TAILS.
HOLDDOWNS - 2.54µm TIN-LEAD MINIMUM OVER 2.54µm NICKEL
- 4 RECOMMENDED PC BOARD THICKNESS OF 1.57.
- 5 PLATING;
CONTACTS - 0.38µm MINIMUM GOLD OVER 2.54µm MINIMUM NICKEL ON MATING AREA. 2.54µm MATTE TIN MINIMUM OVER 2.54µm NICKEL MINIMUM ON SOLDER TAILS.
HOLDDOWNS - 2.54µm MATTE TIN MINIMUM OVER 2.54µm NICKEL

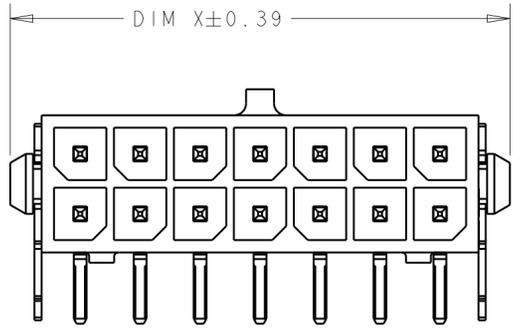
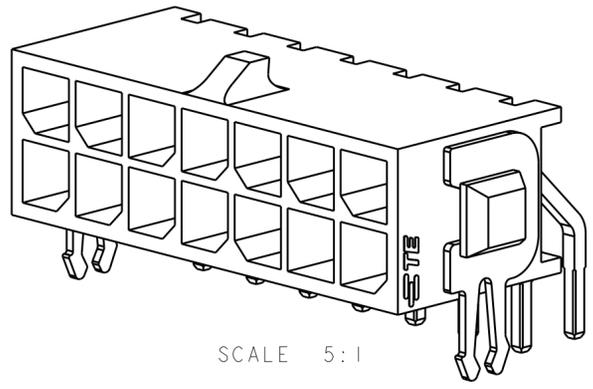
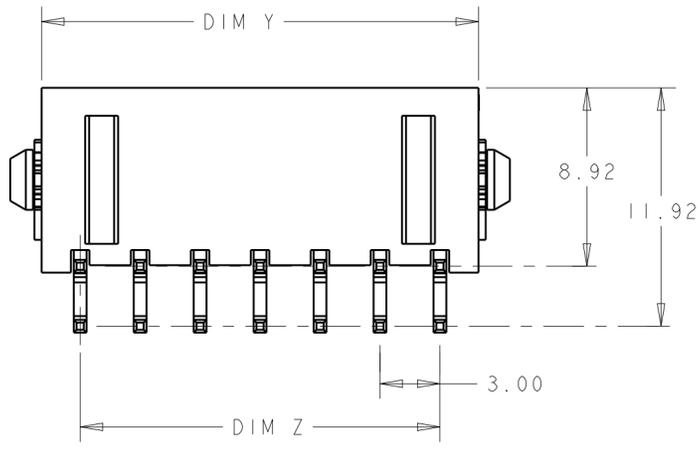

5	36.86	37.30	33.00	40.00	24	5-794678-4
5	33.86	34.30	30.00	37.00	22	5-794678-2
5	30.86	31.30	27.00	34.00	20	5-794678-0
5	27.86	28.30	24.00	31.00	18	4-794678-8
5	24.86	25.30	21.00	28.00	16	4-794678-6
5	21.86	22.30	18.00	25.00	14	4-794678-4
5	18.86	19.30	15.00	22.00	12	4-794678-2
5	15.86	16.30	12.00	19.00	10	4-794678-0
5	12.86	13.30	9.00	16.00	8	3-794678-8
5	9.86	10.30	6.00	13.00	6	3-794678-6
5	6.86	7.30	3.00	10.00	4	3-794678-4
5	3.86	4.30	-	7.00	2	3-794678-2
2	36.86	37.30	33.00	40.00	24	2-794678-4
2	33.86	34.30	30.00	37.00	22	2-794678-2
2	30.86	31.30	27.00	34.00	20	2-794678-0
2	27.86	28.30	24.00	31.00	18	1-794678-8
2	24.86	25.30	21.00	28.00	16	1-794678-6
2	21.86	22.30	18.00	25.00	14	1-794678-4
2	18.86	19.30	15.00	22.00	12	1-794678-2
2	15.86	16.30	12.00	19.00	10	1-794678-0
2	12.86	13.30	9.00	16.00	8	794678-8
2	9.86	10.30	6.00	13.00	6	794678-6
2	6.86	7.30	3.00	10.00	4	794678-4
2	3.86	4.30	-	7.00	2	794678-2
FINISH	DIM Y	DIM W	DIM Z	DIM X	NO. OF POSN.	PART NUMBER

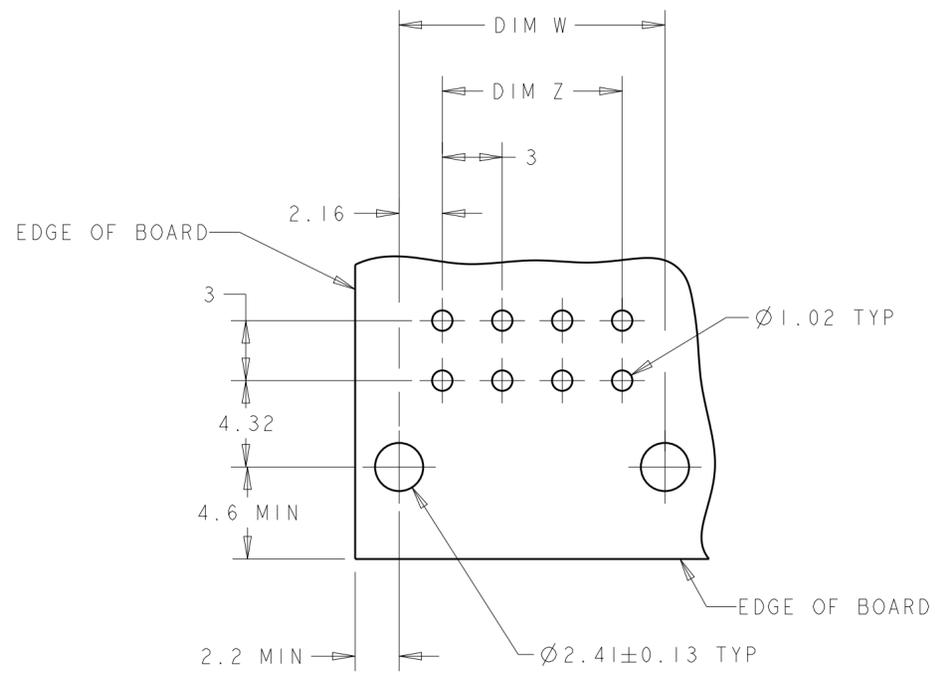

RECOMMENDED PCB LAYOUT (COMPONENT SIDE) 4



THIS DRAWING IS A CONTROLLED DOCUMENT.

DIMENSIONS: mm	TOLERANCES UNLESS OTHERWISE SPECIFIED:	DWN B. HAYMAKER 12AUG99	TE Connectivity
	0 PLC ±	CHK K. COBLE 12AUG99	
	1 PLC ±	APVD K. COBLE 12AUG99	
	2 PLC ±0.13	NAME	
	3 PLC ±	PRODUCT SPEC	THRU-HOLE, RIGHT ANGLE, 15 GOLD HEADER, MECHANICAL BOARDLOCK, DUAL ROW, MICRO MATE MATE-N-LOK™
	4 PLC ±	APPLICATION SPEC	SIZE CAGE CODE DRAWING NO RESTRICTED TO
	ANGLES ±	WEIGHT	A2p0779C-794678
	FINISH ±	CUSTOMER DRAWING	SCALE 4:1 SHEET 1 OF 1 REV G